

Antrag auf Einreise in ein geschütztes Gebiet

Name des Reisenden:

Gedanken des Reisenden:

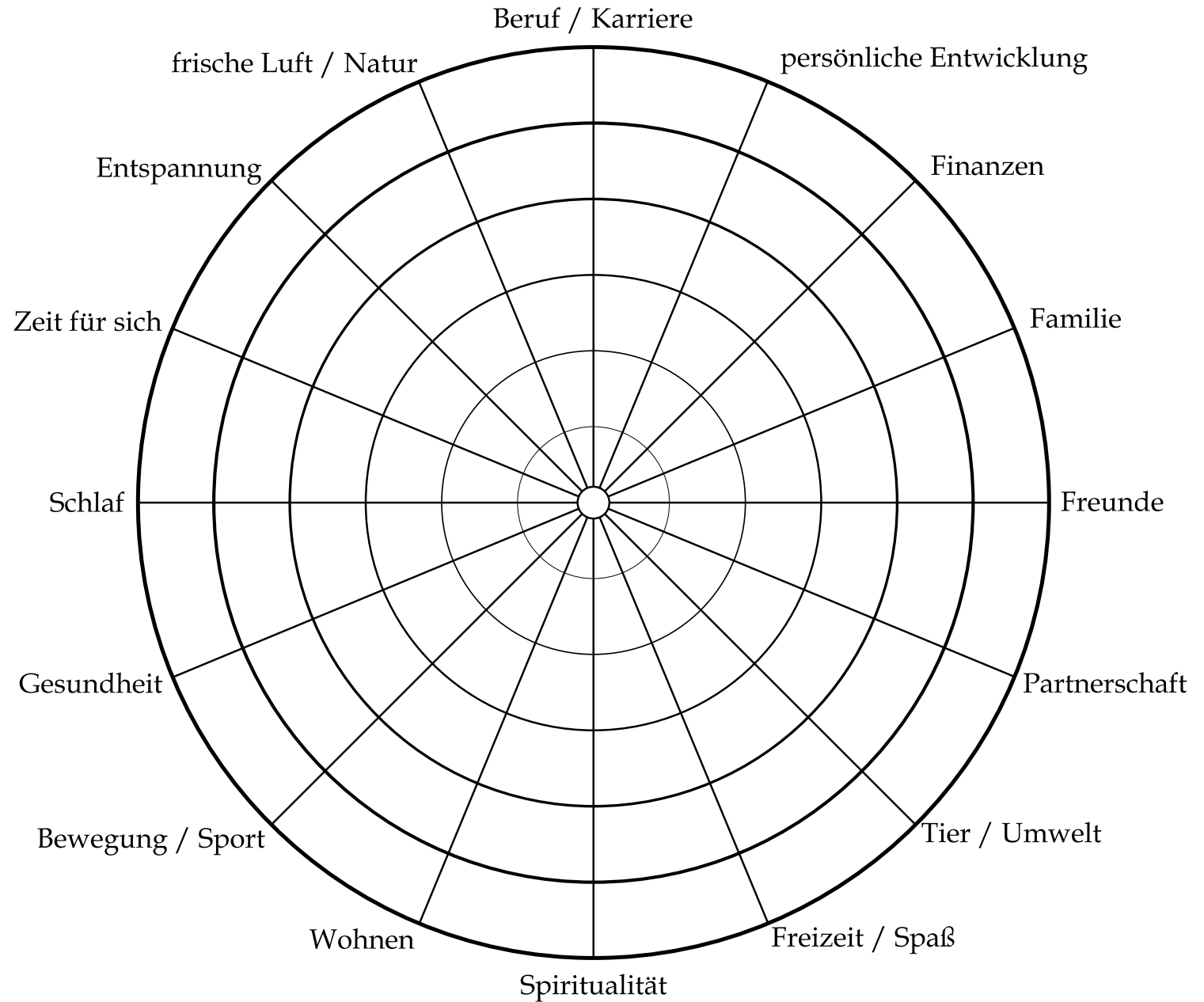

Meine persönliche Galerie

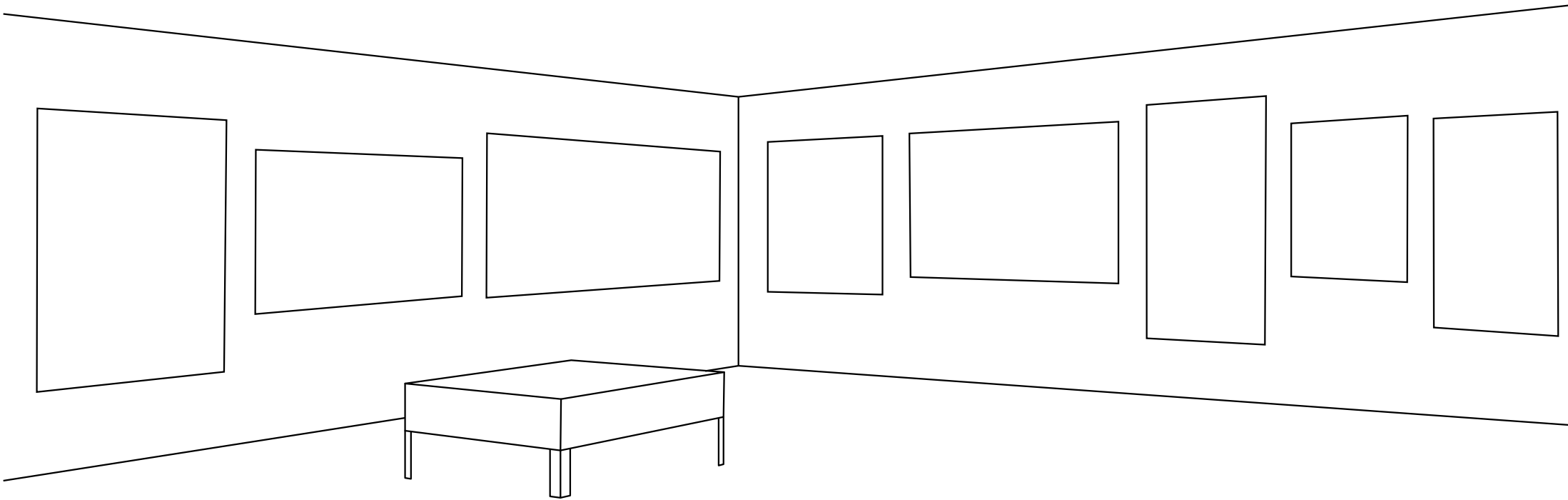

Meine Wunsch-Bilder für die Galerie

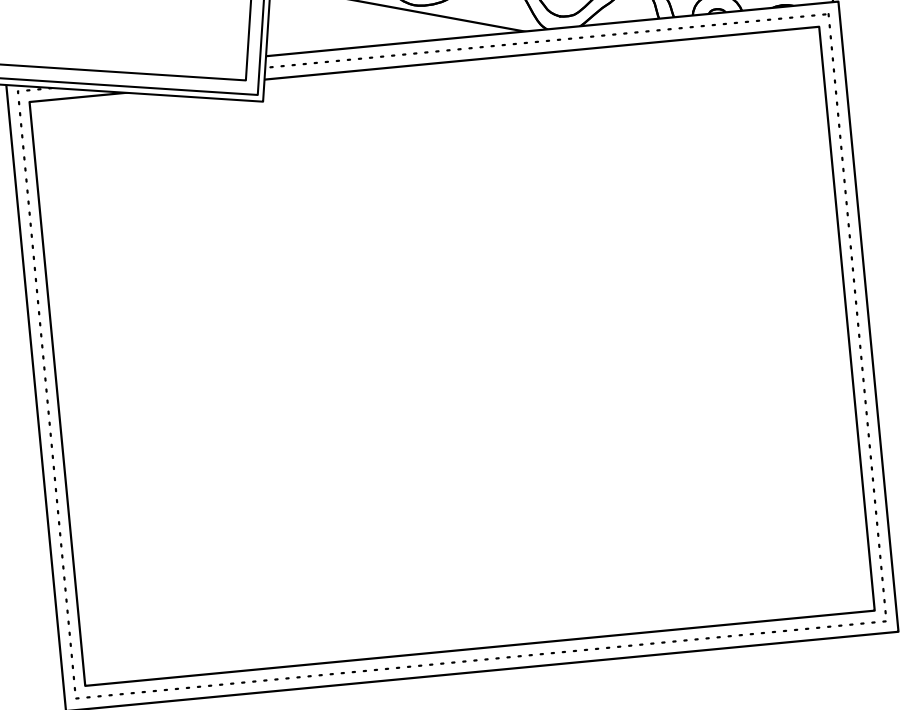
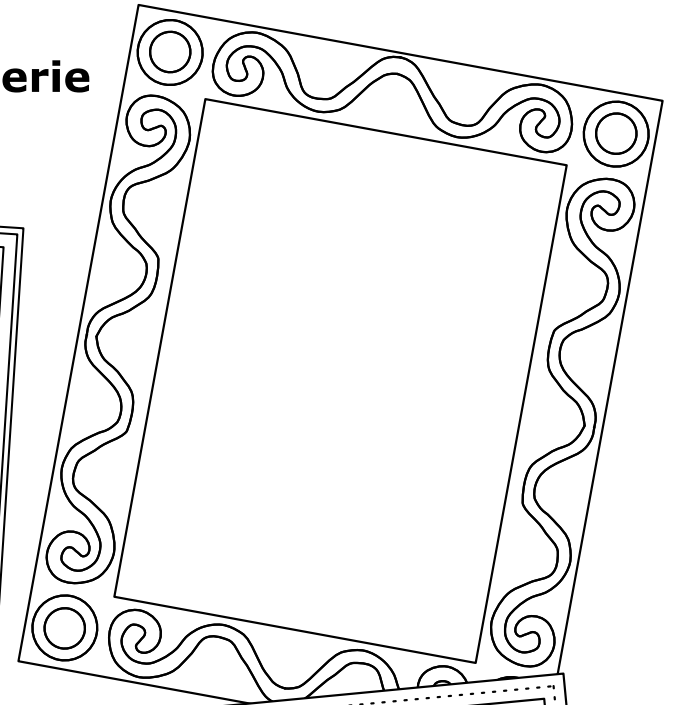
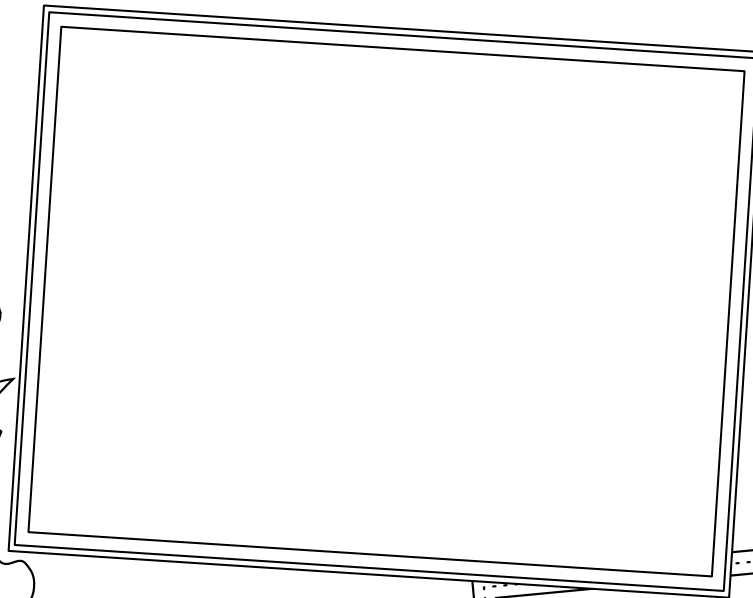
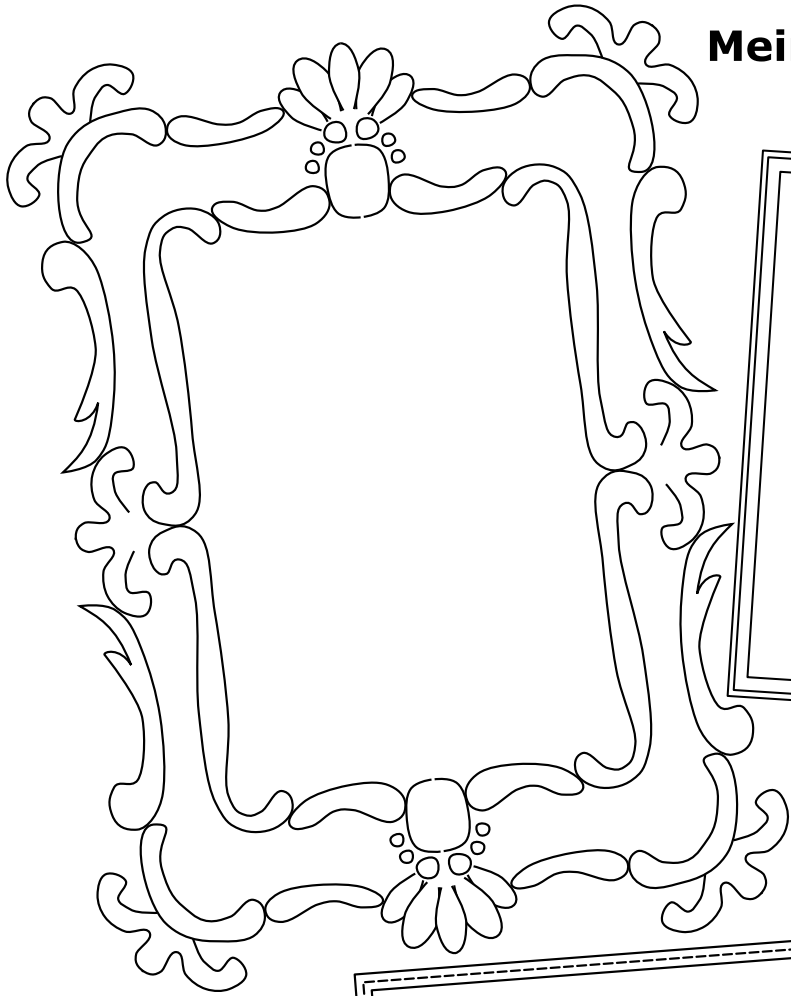

Werte-Paare

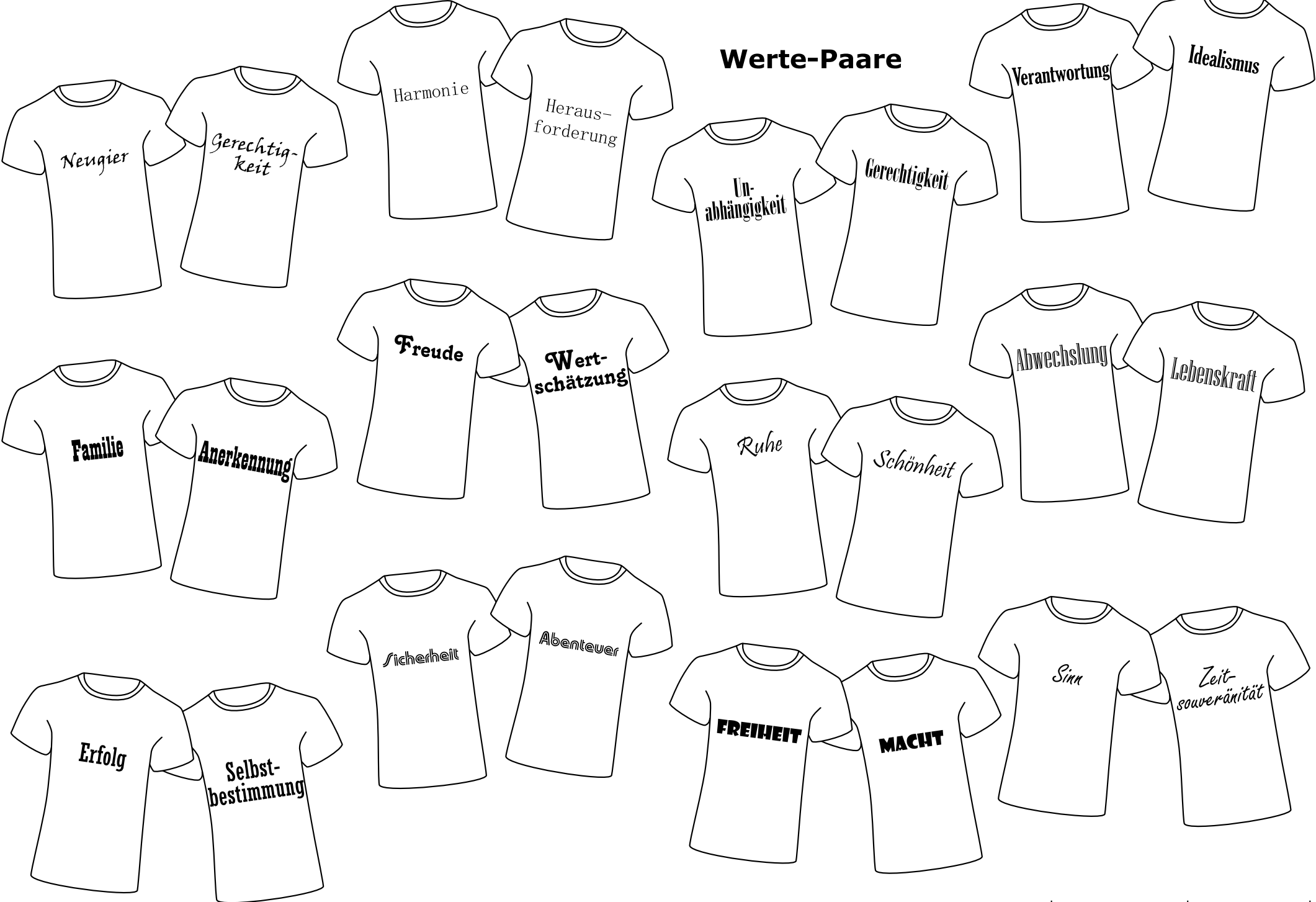

Werte

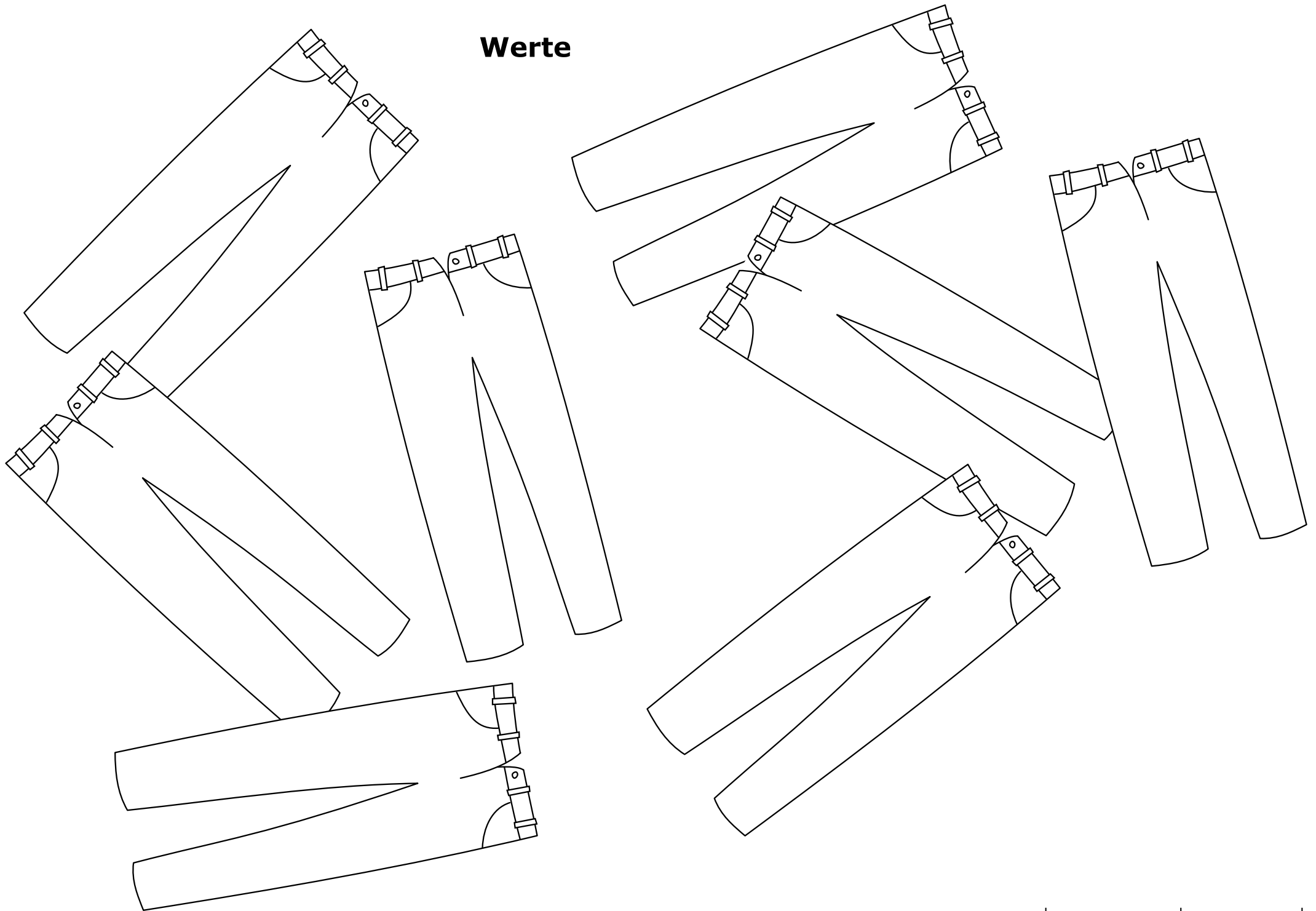

Meine wichtigsten Werte

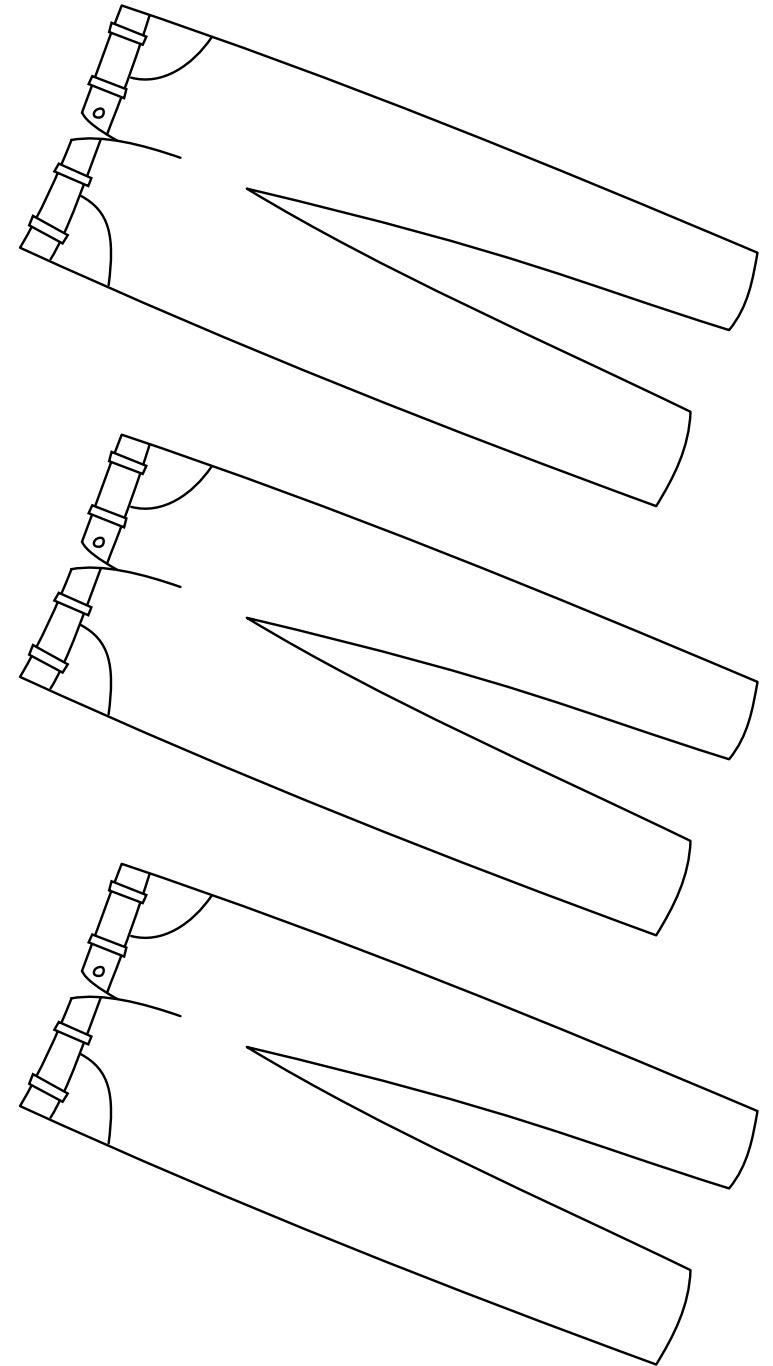
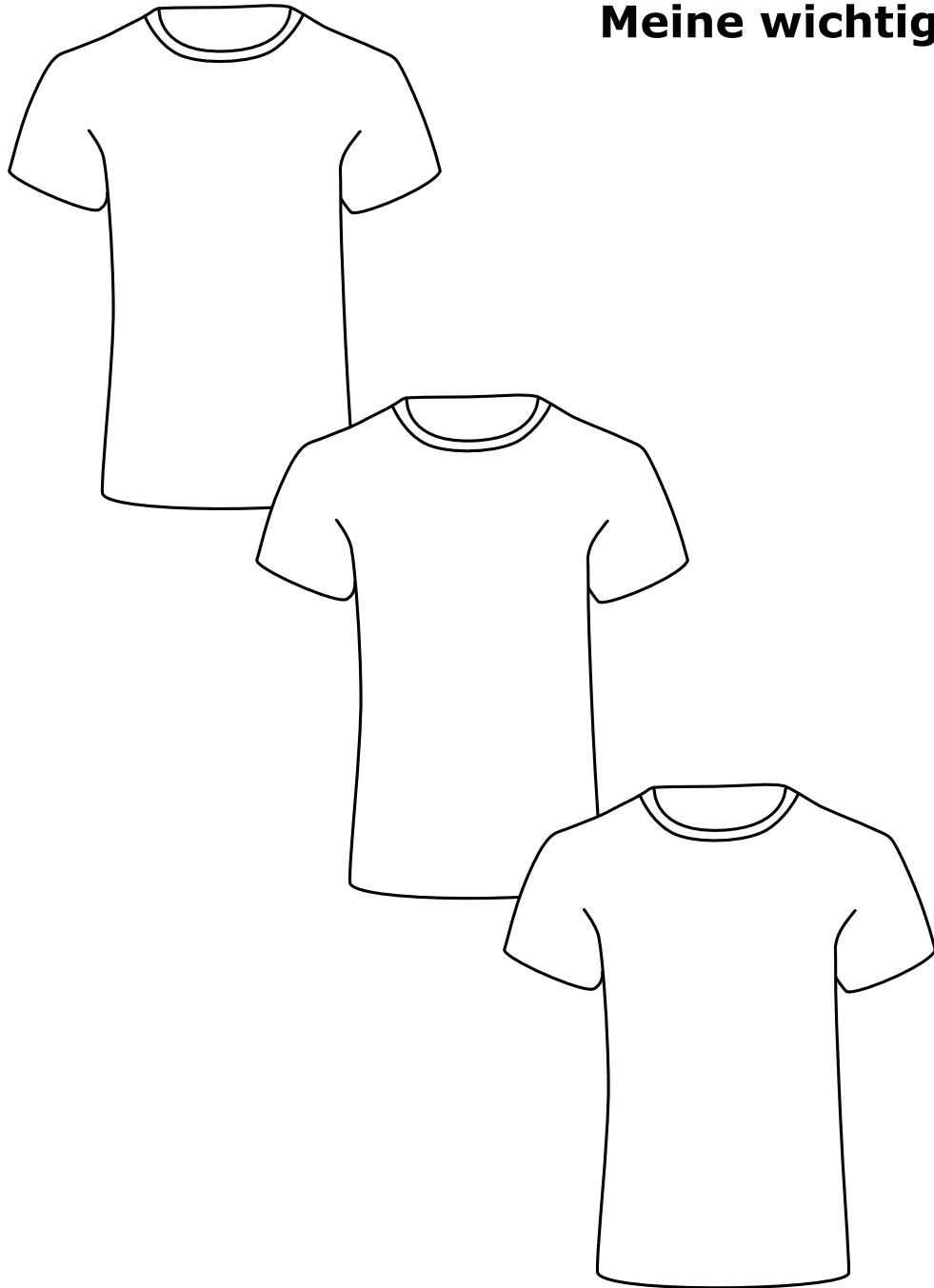

Gesundheit

förderlich für
meine seelische
Gesundheit

förderlich für meine
körperliche
Gesundheit

was mir nicht gut tut

--	--	--	--	--	--	--	--

körperliche Gesundheit

--	--	--	--	--	--	--	--

seelische Gesundheit